

LWS INDUSTRIES – CHECK PRINT			
	NAME	SIGNED	DATE
ENGINEER	L. A. YIP	<i>[Signature]</i>	2014-10-11
SENIOR ENG.	L. A. YIP	<i>[Signature]</i>	2014-10-11
DRAFTED	L. A. YIP	<i>[Signature]</i>	2014-10-11
BACK CHECK	L. A. YIP	<i>[Signature]</i>	2014-10-11

COBBLESTONE GENERATOR MAY BE EITHER THERMAL EXPANSION 'IGNEOUS EXTRUDER' OR EXTRA UTILITIES 'TRANSFER NODE' WITH 'WORLD INTERACTION UPGRADE'.

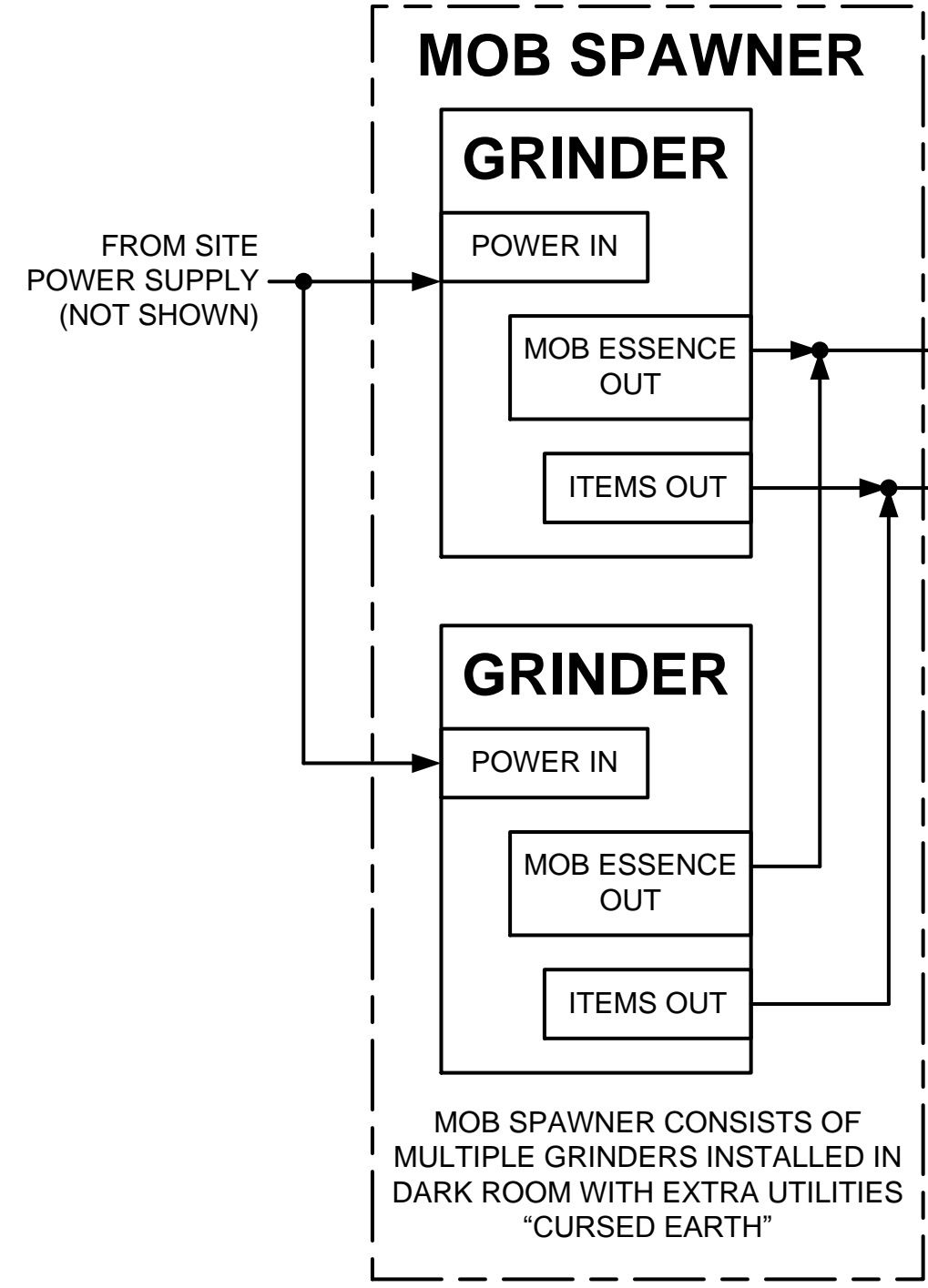

### CHAIN ARMOUR RECYCLING

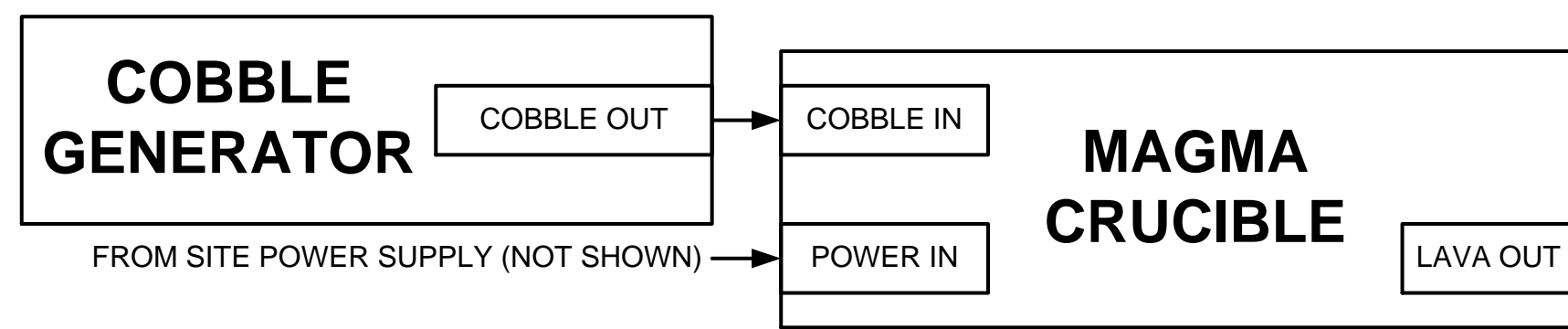
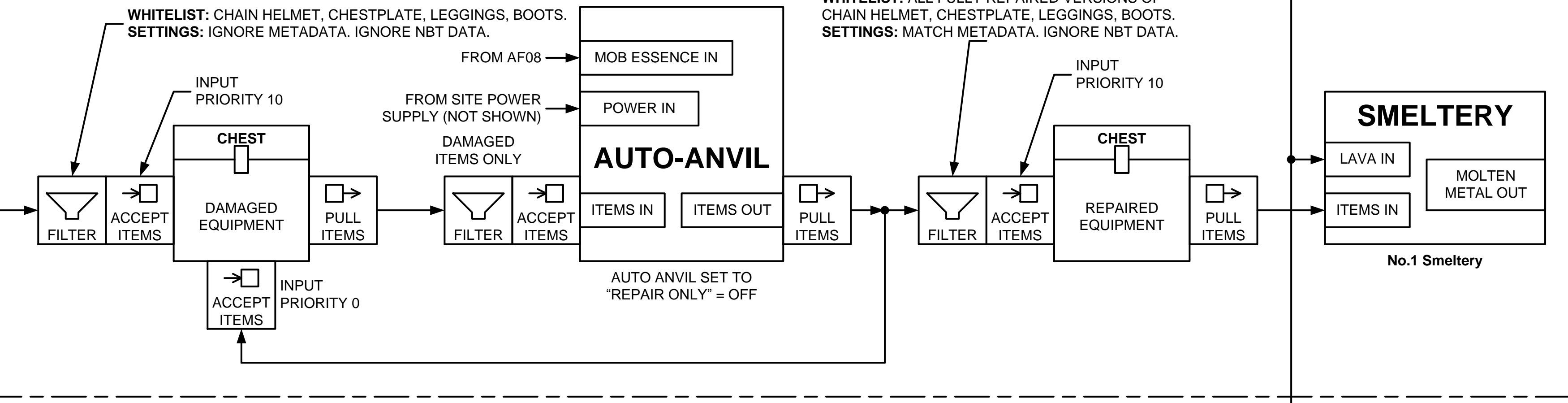

### GOLD ARMOUR RECYCLING

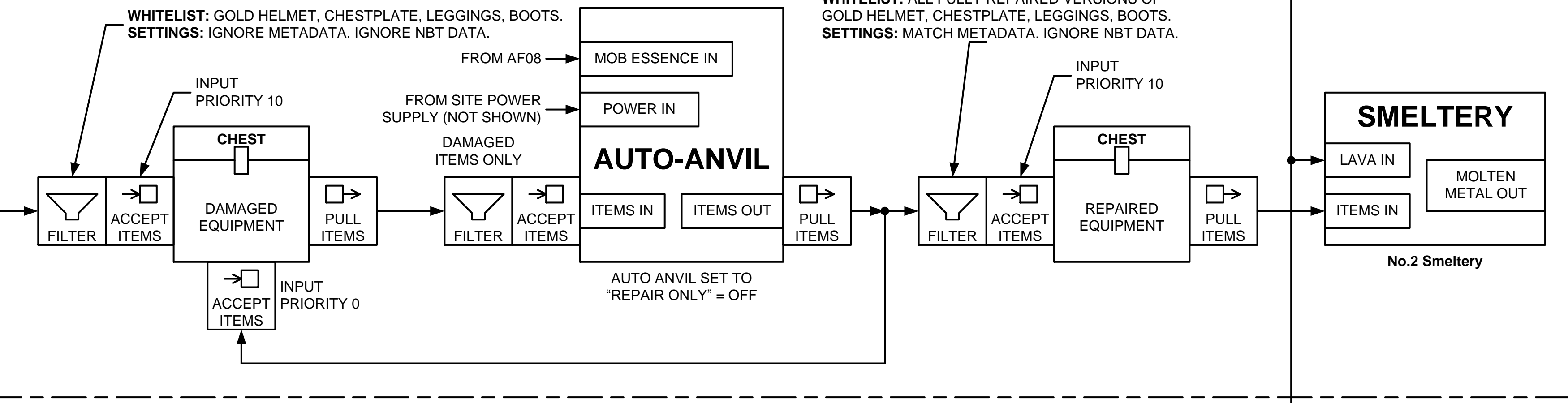

### IRON EQUIPMENT RECYCLING

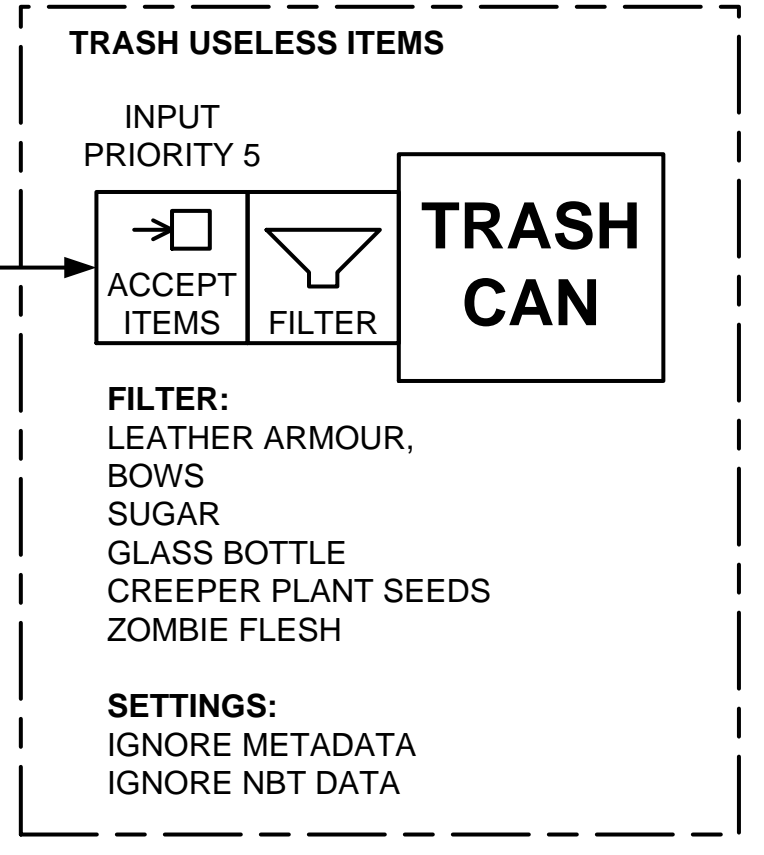
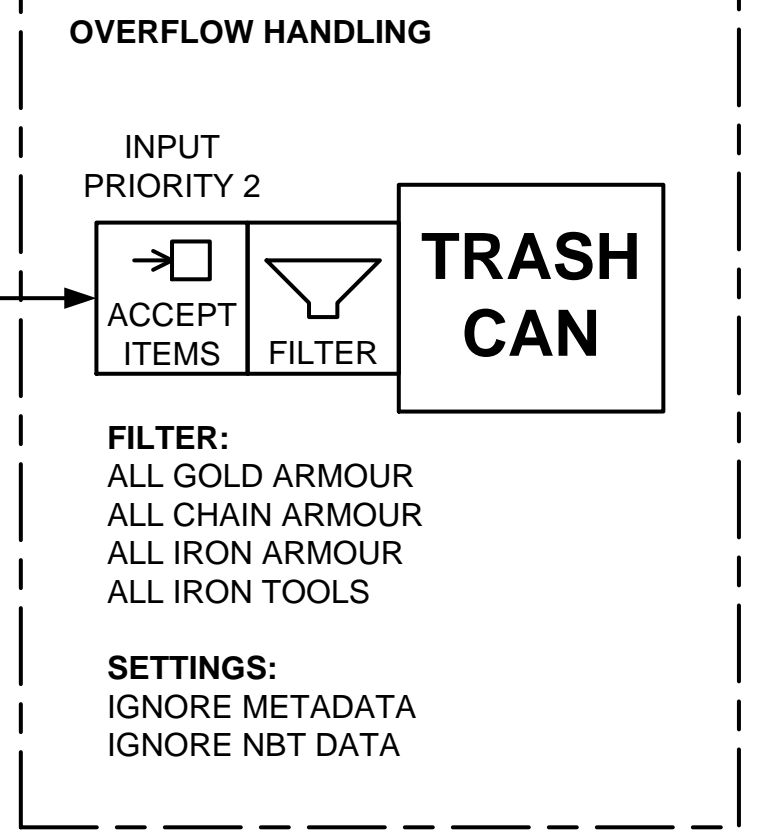
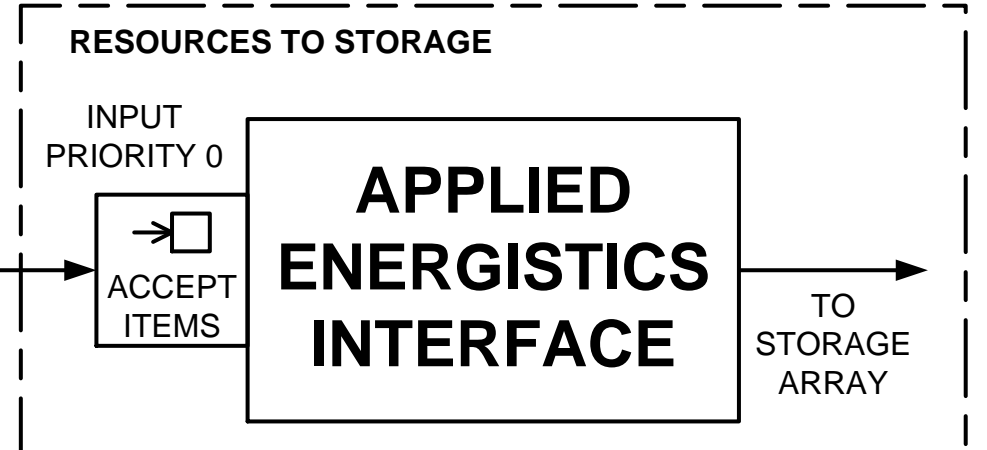
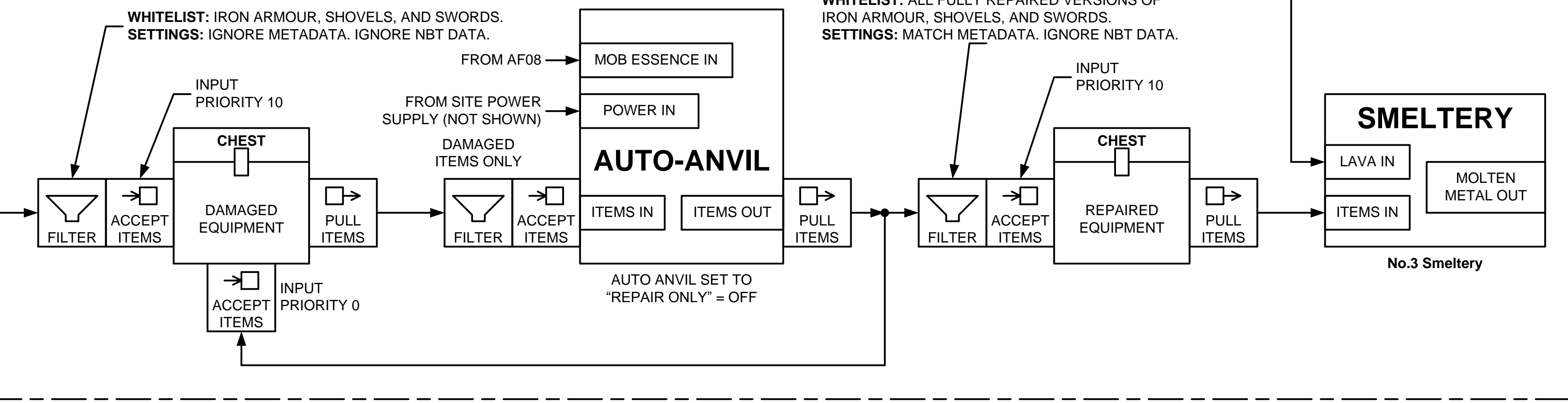

- GENERAL NOTES:**
- ENDER IO 'ITEM CONDUITS' USED FOR ALL ITEM TRANSPORT.
  - ALL ITEM FILTERS ARE ENDER IO 'ADVANCED ITEM FILTER'.
  - ALL 'PULL ITEMS' INTERFACES OF ENDER IO ITEM CONDUITS ARE SET TO REDSTONE MODE 'ALWAYS ACTIVE'.
- DRAWING CONVENTIONS:**
- ALL INPUTS TO A BLOCK ENTER FROM THE LEFT OR TOP. ALL OUTPUTS FROM A BLOCK EXIT FROM THE RIGHT OR BOTTOM.
- EQUIPMENT:**
- AUTO-ANVIL – MINEFACTORY RELOADED  
SMELTERY - TINKER'S CONSTRUCT  
MAGMA CRUCIBLE – THERMAL EXPANSION  
GRINDER – MINEFACTORY RELOADED
- CONSTRUCTION NOTES:**
- VERIFY LOCATION OF ALL EXISTING SERVICES BEFORE CONSTRUCTION BEGINS. IF ANY SERVICE CLASHES ARE FOUND, RAISE THE ISSUE TO THE PRINCIPAL IN THE FIRST INSTANCE.
  - EXECUTE ALL WORK NEATLY WITH ALL CONDUIT WORK RUNNING PARALLEL TO THE LINES OF EXISTING STRUCTURES, ALL TO THE SATISFACTION OF THE PRINCIPAL.
  - REINSTATE ALL EARTHWORKS TO THE SATISFACTION OF THE PRINCIPAL USING CLEAN FILL.

**FOR CONSTRUCTION**

						NOT TO SCALE		1 OF 1				MINECRAFT - BEVO'S TECH PACK					
						SCALE – ALL DIMENSIONS IN MM U.N.O.		SHEET				MOB GRINDER					
						0 20 40 60 80 100						METAL SCAVENGING PROCESS					
						ORIGINAL DRAWING SIZE A1 – 100 MILLIMETRE PAPER SCALE						BLOCK DIAGRAM					
A						ISSUED FOR CONSTRUCTION.		L.A.YIP		2014-10-11		DRAWING TITLE					
REV.						ISSUE		DRAWN		CHECKED		APPROVED					
01						02		03		04		05					
06						07		08		09		10					
11						12		13		14		15					
16						17		18		19		20					
21						22		23		24		25					
26						27		28		29		30					
31						32		33		34		35					
36						37		38		39		40					
FILE NAME						Mob Grinder Block Diagram.vsd						PROJECT NUMBER		DRAWING NUMBER		REVISION	
												XYZZY		271828-314.1		A	